

IMECE2005-82734

ASYMPTOTIC SOLUTIONS OF EFFECTIVE THERMAL CONDUCTIVITY

P. Karayacoubian*, **M. Bahrami†**, **J. R. Culham‡**

Microelectronics Heat Transfer Laboratory
 Department of Mechanical Engineering
 University of Waterloo, Waterloo, Ontario, Canada N2L 3G1

ABSTRACT

A general predictive model for the effective thermal conductivity of mixtures is developed. In the limit of very small particle volume fractions, a limiting case is approached where the effective medium theory of Maxwell holds. At higher solid fractions, an analytical model for the conductivity of a packed bed of spheres is developed. These two limiting asymptotic solutions are then combined using a blending procedure. The result is a semi-analytical model that is valid over the full range of solid fractions. The model shows that in addition to the conductivities of the particle/matrix and the solid fraction, the degree of wetting of the particles by the matrix is an important parameter in estimating the effective thermal conductivity of the mixture. In addition, the effect of entrapped air is captured through the definition of an effective volume fraction in Maxwell's model. The model shows good agreement with experimental data.

NOMENCLATURE

A	cross-sectional area, m^2
a	contact spot radius, m
C	correction parameter
$D(r)$	distance between contacting surfaces at r , m
k	thermal conductivity, W/mK
k^* , k_p^*	non-dimensional mixture, particle conductivity

L_c	characteristic cell length, m
$L\phi$, $H\phi$	low, high ϕ
n	blending parameter
Q	heat flow, W
R	thermal resistance, K/W
r	radial length measured from contact point, m
SC , FCC	simple cubic, face-centered cubic
T	temperature, K
V	volume, m^3
x	point contact to edge of void distance, m

Greek Symbols

ϕ	solid (particle) volume fraction
ρ	radius of curvature, m
θ	void angle, rad

Subscripts

a	air
c	characteristic
eff	effective
G	gap
j	total
L	macroconstriction/contact
m	matrix
p	particle
s	harmonic mean

*Graduate Student, pkarayac@mhtlab.uwaterloo.ca

†Post-doctoral Fellow, Member ASME

‡Associate Professor, Member ASME, Director of Microelectronics Heat Transfer Laboratory

INTRODUCTION

Numerous research initiatives have addressed the minimization of thermal joint resistance in microelectronic applications. Particle-laden polymers are the latest Thermal Interface Materials (TIMs) being investigated for such applications. The desired thermal properties (conductivity, compliance, etc.) can be obtained through careful selection of properties of the particle/matrix materials. A fundamental problem which remains to be addressed is how to develop general predictive models for the effective thermal conductivity of the mixture.

Various approaches for estimating mixture conductivities have been developed. There are as a consequence many models available in the literature. Many are semi-theoretical and require data for necessary constants. See [1] for a brief literature review.

Part of what makes the modeling of the effective thermal properties of mixtures difficult is that certain mechanisms of heat transfer are endemic to particular *ranges* of solid fraction. Effective medium theory (EMT) [2], for example, can only be used accurately for low volume fractions ($L\phi$), Fig. 1a, a consequence of neglecting the effects of neighboring particles on lines of heat flow. As the volume fraction is increased, some authors have noted a percolation threshold [3] beyond which the conductivity increases much more rapidly than is predicted by EMT. It is imagined that the mixture eventually approaches a condition analogous to a packed bed, Fig. 1c, where models developed for these conditions become more appropriate.

In the present work, the above mentioned models (EMT, packed bed) are considered two limiting asymptotic solutions. At low particle volume fractions, Maxwell's model (EMT) is valid. As the particle volume fraction is increased, Fig. 1b, there is a smooth transition where the mixture conductivity continuously approaches that predicted by a packed bed model. A simplified model (spherical particles, no applied load) is developed for the packed bed in the present paper where the effects of particle wetting are considered. These two solutions are combined using the Churchill-Usagi blending procedure [4]. The model is compared with experimental data and shown to give good agreement. In addition, the effect of entrapped air is captured to a first approximation through the definition of an effective volume fraction in Maxwell's model. This gives excellent agreement with experimental data.

MODEL DEVELOPMENT

The mixture is first characterized for the two limiting solid fraction regimes. The assumptions of the model are stated below. The first three assumptions apply to the entire range of solid fractions. Assumptions 4 to 8, however, specifically hold for high solid fractions ($H\phi$) where the particles begin to make contact. In this range of ϕ , imperfect wetting results in the presence of an air void in the vicinity of the point contact.

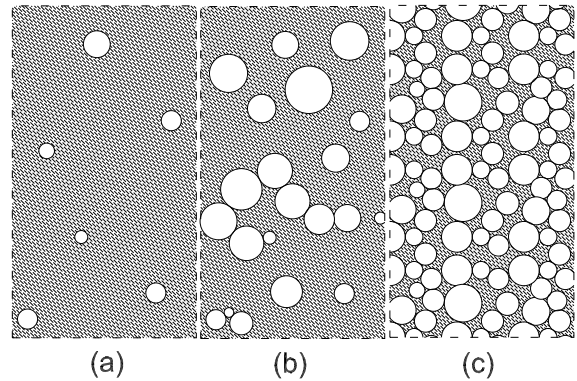

Figure 1. A PARTICLE-LADEN POLYMER MIXTURE FOR (a) LOW SOLID FRACTIONS ($L\phi$), (b) INTERMEDIATE SOLID FRACTIONS, AND (c) HIGH SOLID FRACTIONS ($H\phi$)

Assumptions

1. The particles are smooth spheres of uniform size
2. The particles and matrix are homogeneous and isotropic
3. Boundary resistance is neglected
4. Heat transfer across the gap occurs only by conduction
5. The particles support no load (point contact at high solid fraction)
6. The particles are isothermal, $k_p \gg k_m$
7. Rarefaction effects in the gap between contacting particles are negligible
8. Heat transfer through the air void is negligible

Low solid fraction limit ($L\phi$)

At low solid fractions, the disturbing effect on the course of the heat flow by neighboring particles is neglected. Eucken [5] adapted a model developed by Maxwell for the effective electrical resistance of a substance into which are disseminated small spheres. In his analysis, a basic spherical cell of the matrix can be identified wherein a spherical particle is embedded. An effective homogeneous medium surrounds this basic cell, Fig. 2.

If the spheres were dispersed in a matrix with regular lattice arrangement, a cube would be chosen as the basic cell. The spheres are randomly dispersed; therefore, a convenient *average* shape is the sphere.

The result of solving the Laplace equations for the 3 media

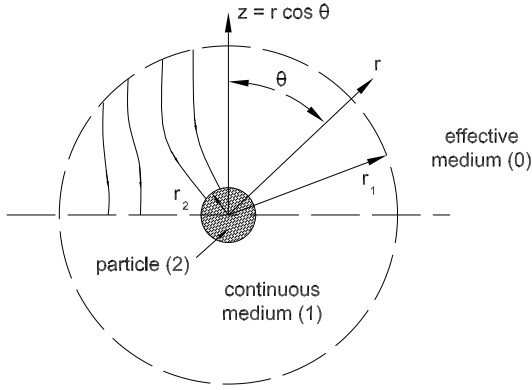

Figure 2. EFFECTIVE MEDIUM THEORY

with appropriate boundary conditions gives [5]

$$k^* = \frac{k}{k_m} = \frac{k_p^*(1+2\phi) + 2(1-\phi)}{k_p^*(1-\phi) + (2+\phi)} \quad (1)$$

where $k_p^* = k_p/k_m$, k_p is the conductivity of the particle, and k_m is the conductivity of the matrix.

In taking the limit as $k_p^* \rightarrow \infty$ in Eq. (1), the non-dimensional conductivity of the mixture is seen to approach

$$k^* = \frac{k}{k_m} = \frac{1+2\phi}{1-\phi} \quad (2)$$

This enhancement in the conductivity of the matrix is practically reached once $k_p^* > \sim 100$ for typical volume fractions. Any efforts directed towards increasing the effective thermal conductivity of a material are thus wasted if entirely directed towards the search for a more highly conductive dispersed phase. Other factors must be considered.

High solid fraction limit ($H\phi$)

In this study, when the solid fraction is large, the mixture is treated as a randomly packed bed of smooth spheres of uniform size. The total thermal resistance is calculated from a network of conduction paths. The effective conductivity of the composite media is determined from this total resistance and the geometry of a characteristic cell.

A regularly packed bed is a basic arrangement of spheres uniform in size repeated throughout. A characteristic cell whose thermal properties represent those of the entire bed can thus be identified. Although there are many different ways of arranging the spheres, Tien and Vafai [6] have shown that the effective thermal conductivity of a randomly packed bed presents two limits. As an upper bound, the packing arrangement can be considered

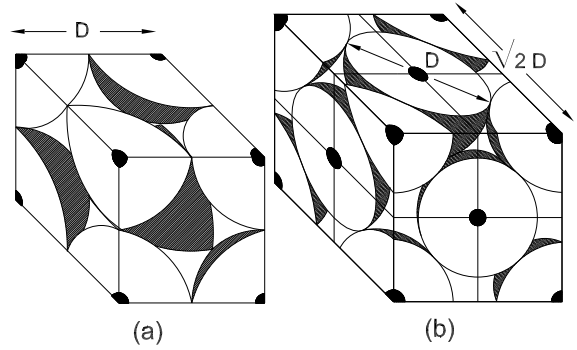

Figure 3. PACKING ARRANGEMENTS FOR (a) SIMPLE CUBIC (SC) AND (b) FACE-CENTERED CUBIC (FCC) PACKED BEDS

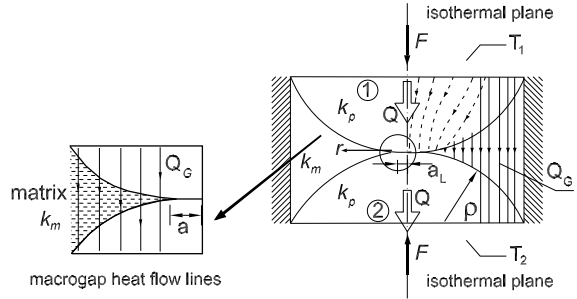

Figure 4. HEAT TRANSFER MODES FOR SMOOTH SPHERICAL PARTICLES BROUGHT INTO CONTACT UNDER LOAD [7]

to be face-centered cubic (FCC) and as a lower bound, simple cubic (SC), Fig. 3.

Only these two limiting arrangements (SC, FCC) are considered in the present study. The solid fraction corresponding to each of the two packing arrangements are $\phi_{SC} = \pi/6 \simeq 52\%$ and $\phi_{FCC} = \sqrt{2}\pi/6 \simeq 74\%$. We develop a model so that we have $k(\phi_{SC})$ and $k(\phi_{FCC})$. These points are joined linearly and assumed to constitute the second asymptote.

When two smooth spherical particles are brought into contact under load, Fig. 4, a circular contact spot is formed. Heat can be transferred from one sphere to the other by conduction through the contact area, conduction through the substance in the gap, and radiation across the gap. In this study, convection and radiation are neglected.

The total thermal resistance for a characteristic cell (R_j) is determined from the parallel combination of the contact and gap resistances, Fig. 5. By neglecting the bulk and layer resistances

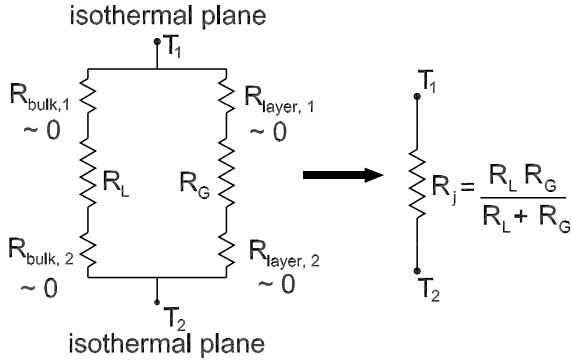

Figure 5. THERMAL RESISTANCE (SCHEMATIC AND NETWORK OF RESISTORS)

Table 1. CHARACTERISTIC LENGTHS AND RESISTANCES: SC, FCC

Packing	ϕ	L_c	R_c
SC	0.52	D	R_j
FCC	0.74	$\sqrt{2}D/2$	$R_j/2$

of the particles, the total thermal resistance can be written as

$$\frac{1}{R_j} = \frac{1}{R_L} + \frac{1}{R_G} \quad (3)$$

where R_L is the contact resistance associated with conduction through the contact spot and R_G is the gap resistance. The effective thermal conductivity is still a function of (k_p, k_m, \dots) despite our simplification of the resistive paths. This is because $R_L = f(k_p, \dots)$ and $R_G = f(k_m, \dots)$.

It follows directly from the definition of thermal resistance ($R = \Delta T/Q$) and Fourier's law that

$$k = \frac{L_c}{R_c A} \quad (4)$$

where L_c is the characteristic length, R_c is the resistance of the cell, and A is the cross-sectional area (L_c^2), Table 1. The characteristic length is selected as shown in Fig. 3. A 1/8 th cell represents FCC packing. Note that $R_{c,FCC} = R_j/2$ as there are 4 half contact regions in parallel in the cell. Analytical models of the contact and gap resistances are required at this point so that a full solution of the effective conductivity of the bed for high solid fractions in closed form can be presented.

Contact resistance Yovanovich et al. [8] have shown that if the contact spot between two spheres is kept small, the contact region can be accurately approximated as a half-space. The contact resistance is thus $1/2k_s a$ where k_s is the harmonic mean thermal conductivity and a is the contact spot radius. In the present study, the load supported by the particles is assumed negligible and taken as zero so that the spheres make point contact. Conduction across the joint is thus impossible since there is no area ($a \rightarrow 0$) over which any heat flux can occur. The resistance associated with conduction across the contact spot approaches infinity: $R_L \rightarrow \infty$.

Gap resistance Additional thermal resistance results as heat is conducted through the substance in the gap. The heat conducted across the gap can be written from Fourier's law integrated over the cross-sectional gap area as

$$Q_G = \int \int_{A_G} \frac{k_m \Delta T}{D(r)} dA_G \quad (5)$$

where k_m is the conductivity of the matrix, A_G is the cross-sectional area of the flat surface, ΔT is the temperature difference between the contacting surfaces (equivalent sphere and flat), and $D(r)$ is the distance between the contacting solids at a given radius, Fig. 6.

From the definition of thermal resistance and recognizing that $dA_G = 2\pi r dr$ we can write the gap resistance as

$$R_G = \frac{1}{2\pi k_m} \left(\int_x^{b_L} \frac{r}{D(r)} dr \right)^{-1} \quad (6)$$

where for spherical particles

$$D(r) = \rho - \sqrt{\rho^2 - r^2} \quad (7)$$

The term b_L represents the chord length of the gap. For an SC arrangement, $b_L = \rho$ and for an FCC arrangement, $b_L = \rho \tan \psi$ where ψ is 40° , a result of geometry [7].

Although there is only a point contact made, the integral cannot be taken quite to the limit $r = 0$. In reality, imperfect wetting of the particles by the matrix will result in the presence of an air void in the vicinity of the point contact, Fig. 6. The matrix-air interface of the void makes an angle with the point contact which is herein referred to as the *void angle* (θ). The void angle is thought to be related to the relative surface energies of the matrix, air, and particles, as well as the temperature and pressure difference across the interface [9]. The air pockets may be eliminated if sufficient heat energy is applied but is practically

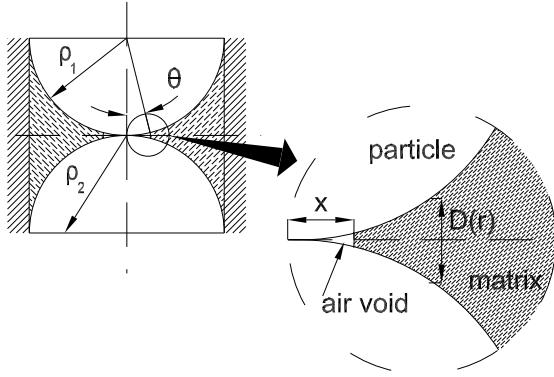

Figure 6. IMPERFECT WETTING OF THE SURFACES RESULTS IN A VOID IN THE VICINITY OF THE POINT OF CONTACT

very difficult to achieve. The distance from the point contact x is related to the void angle as

$$x = \rho \tan \theta \quad (8)$$

defining the lower bound of the integral in Eq. (6).

Any heat transfer through the air in the void is neglected. The integral in Eq. (6) can be solved analytically and so an explicit solution of R_G in closed form can be written as

$$R_G = \frac{1}{2\pi k_m} \left[\rho \left(\ln \left(\frac{1-A}{1-B} \right) + A - B \right) \right]^{-1} \quad (9)$$

where $A = \sqrt{1 - \tan^2 \psi}$ and $B = \sqrt{1 - \tan^2 \theta}$. ψ_{SC} is taken as 45° .

The void angle θ is determined by evaluating Eqs. (4) and (9) with experimental data at ϕ_{SC} . If data are not available at ϕ_{SC} , the nearest data point is extrapolated and the same procedure is applied. It is then assumed that $\theta_{SC} = \theta_{FCC}$.

Total thermal resistance The thermal resistance for the two distinct paths is completely characterized: $R_L \rightarrow \infty$ and R_G is given by Eq. (9). The total thermal resistance is thus equivalent to the gap resistance ($R_j = R_G$, Eq. (3)) and from Eq. (4), we have a relationship for the effective conductivity of the packed bed. It is seen that at very high solid fractions, the effective conductivity of the composite is not a function of the conductivity of the dispersed phase but only of the conductivity of the matrix and the degree of wetting as quantified by the void angle (the radii of the contacting particles cancel).

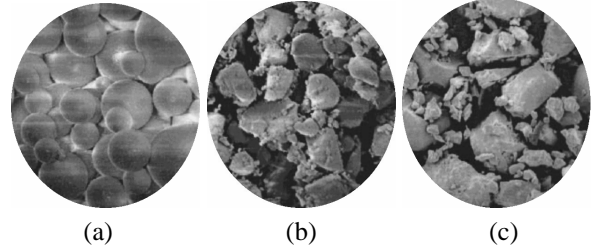

Figure 7. SEM MICROGRAPHS OF (a) SILICA, (b) ALUMINA, AND (c) SCAN PARTICLES [10]

Intermediate solid fraction

We note that in the intermediate range of volume fractions ($\sim 0.1 \leq \phi \leq \sim 0.5$), $k_{L\phi} < k < k_{H\phi}$ where $k_{L\phi}$ and $k_{H\phi}$ are the asymptotically approached effective conductivities of mixtures for low and high solid fractions. $k_{L\phi} = k(k_p, k_m, \phi)$ is given by Eq. (1). $k_{H\phi} = k(k_m, \theta, \phi)$ is given by the straight line joining $k(\phi_{SC}) = 1/R_j D$ and $k(\phi_{FCC}) = 2\sqrt{2}/R_j D$ where $R_j = R_G$ is given by Eq. (9).

Assuming a smooth transition of the effective conductivity with solid fraction, one can write

$$k = (k_{L\phi}^n + k_{H\phi}^n)^{\frac{1}{n}} \quad (10)$$

The model developed for $H\phi$ is linearized in the log-log domain and blended with the Maxwell model. This simple model captures the behavior of effective thermal conductivity over the full range of particle solid fractions ($0 \leq \phi \leq \phi_{FCC}$). The blending parameter n is estimated using available data.

COMPARISON WITH EXPERIMENTS

In a set of experiments performed by Wong and Bollampally [10], the effective thermal conductivities of epoxy resins filled with ceramic particles like silica, alumina, and silica-coated alumina nitride (SCAN) were determined. The average size of the particles used was 12 to 15 microns. The silica particles were spherical whereas the alumina particles were close to spherical and the SCAN particles, irregular in shape, Fig. 7. The thermal conductivities of the epoxy resin matrix and particles are summarized in Table 2.

The data of [10] for each of the three mixtures are presented in Figs. 8 to 10. The model is applied with $n = 3.5$ and shows good agreement in this range, in particular for the almost spherical alumina particles and irregular SCAN particles in the epoxy resin.

The model predicts an enhancement of $k^*(\phi_{SC}) = 7.7$ for the silica dispersion. This means that the mixture conductivity has reached the particle conductivity ($k^* \cdot k_m \simeq k_p$). Because $k_p/k_m \sim 10$ is not \gg than 1 for the silica dispersion, our assumption

Table 2. THERMAL CONDUCTIVITY OF EPOXY RESIN MATRIX AND PARTICLES (Data from [10])

Constituent	k [W/mK]	Shape
epoxy resin	0.195	(matrix)
silica	1.5	spherical
alumina	36	almost spherical
SCAN*	220	irregular

*silica-coated alumina nitride

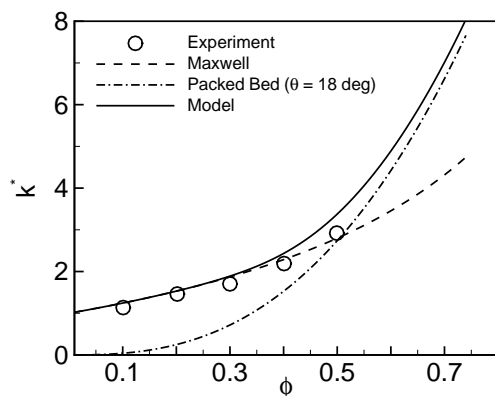

Figure 8. SILICA: EXPERIMENTAL RESULTS AND THEORETICAL PREDICTIONS OF EFFECTIVE THERMAL CONDUCTIVITY WITH SOLID FRACTION (Data from [10])

that the particles are isothermal may not be valid. The additional simplification of neglecting boundary resistance also leads to an overestimate of k . In the alumina and SCAN dispersions, the mixture achieves at best 10% and 3% of the particle conductivity, respectively. Though the particles are likely isothermal in these mixtures, it is questionable that the packed bed model developed in the paper is appropriate since the particle geometries deviated from the assumed spheres.

The enhancement of a mixture's conductivity is often implicitly attributed entirely to the use of particles of higher conductivity. Variables such as geometry and degree of wettability are typically treated as second-order effects. The authors recognize, however, that wetting of the particles is an important parameter in establishing the enhancement for a mixture.

A practical range on the void angle is estimated from these experiments: $1 < \theta < 18$ deg. It is noted that $\theta_{silica} > \theta_{alumina} > \theta_{SCAN}$. The void angle is essentially a fitting parameter in the present formulation of the model. For a more conductive dispersed phase, $k(\phi_{SC})$ is typically higher, which requires lower

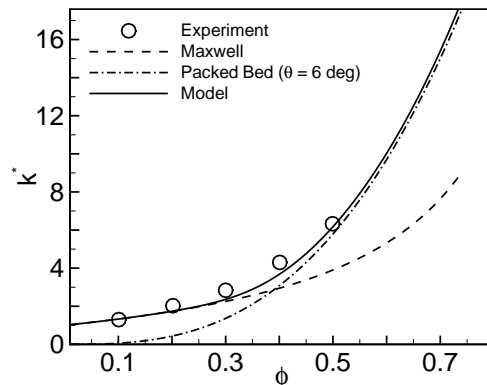

Figure 9. ALUMINA: EXPERIMENTAL RESULTS AND THEORETICAL PREDICTIONS OF EFFECTIVE THERMAL CONDUCTIVITY WITH SOLID FRACTION (Data from [10])

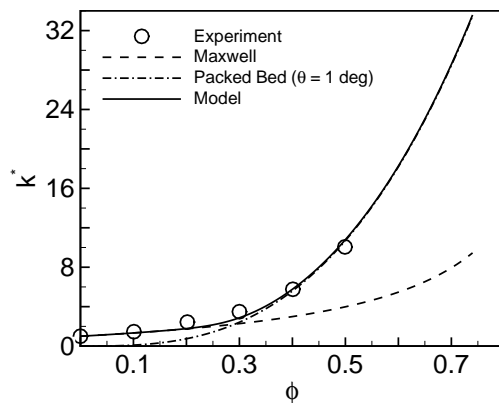

Figure 10. SCAN: EXPERIMENTAL RESULTS AND THEORETICAL PREDICTIONS OF EFFECTIVE THERMAL CONDUCTIVITY WITH SOLID FRACTION (Data from [10])

resistance, Eq. (4), and thus, a smaller void angle, Eq. (9).

Parametric Study

The effect of the conductivity of the dispersed phase on that of the mixture is examined more closely. The effect of entrapped air is also considered and a modified volume fraction is proposed. The sensitivity of the void angle to the calculations is also discussed briefly.

Particle conductivity Maxwell's model shows that the upper limit on enhancement of the matrix with a dispersion of particles is practically reached for $kp/km \approx 100$. Although this model is not appropriate for the full range of particle volume

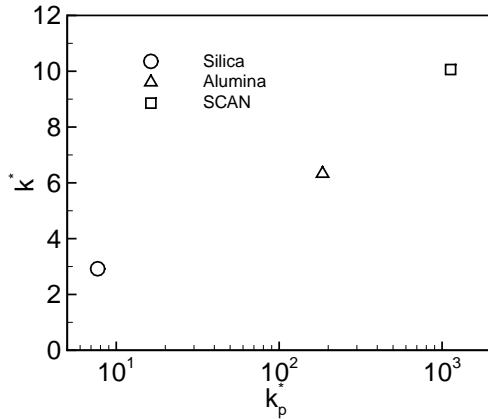

Figure 11. THERMAL CONDUCTIVITY OF MIXTURE A WEAK FUNCTION OF THERMAL CONDUCTIVITY OF PARTICLES ($\phi = 50\%$) (Data from [10])

fractions, this prediction is still observed experimentally even for high volume fractions, Fig. 11. For example, the particle conductivity must be increased by a factor 100 to enhance the conductivity by only 3 times at $\phi = 50\%$. This leads the authors to believe that there are potentially other variables of the mixture, such as the geometry of the particles and the degree to which they are wetted by the matrix, which must now be given further consideration. It is of interest to note that in our model, the mixture conductivity is independent of particle conductivity to a first order approximation at large volume fractions.

Entrapped air Any real mixture of particles in a fluidic matrix will have entrapped air to a certain extent. A recent study by Gowda et al. [11] has indicated the presence of air voids at the particle-resin interface, Fig. 12. A rigorous approach to including this effect in our model would be too complicated to simply annotate at this point; however, to a first approximation, we propose an alternate definition of the volume fraction as

$$\phi_{eff} = \frac{V_p}{(V_p + V_a) + V_m} \quad (11)$$

where the volume of the entrapped air, V_a , has been accounted for in the total volume.

Because $k_{air} < k_m$, a model which neglects the entrapped air gives an overestimate of the mixture conductivity in this respect. To a first approximation, an effective volume fraction can be defined as

$$\phi_{eff} = C\phi \quad (12)$$

where $C > 1$. The parameter C , for now, can be determined from

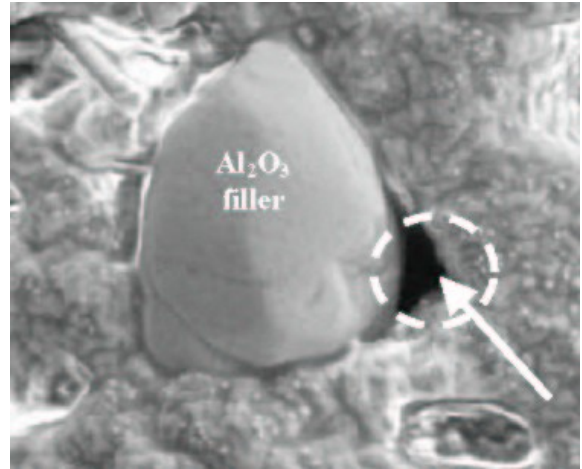

Figure 12. VOID AT PARTICLE-MATRIX INTERFACE [11]

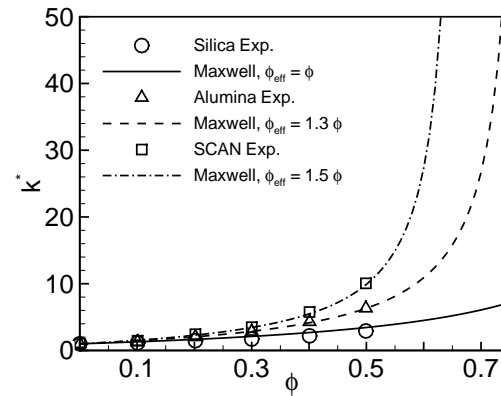

Figure 13. EQUIVALENT VOLUME FRACTION: EXPERIMENTAL RESULTS AND PREDICTIONS OF MAXWELL'S MODEL FOR SILICA, ALUMINA, AND SCAN MIXTURES (Data from [10])

the experiments to illustrate this point. The experimental results of Wong and Bollampoly and the predictions of Maxwell's equation with an effective volume fraction are shown in Fig. 13. The agreement is excellent. Though the authors still concede that Maxwell's model is not valid for the higher volume fractions and a more rigorous approach is required, the illustrative purpose of this exercise – that the effect of the entrapped air can potentially be modeled with an effective volume fraction – should not be understated.

Void angle The effective thermal conductivity of the mixture estimated with the present model is extremely sensitive to the void angle, Fig. 6. This is especially true for high volume fractions. Figure 14 shows the effective thermal con-

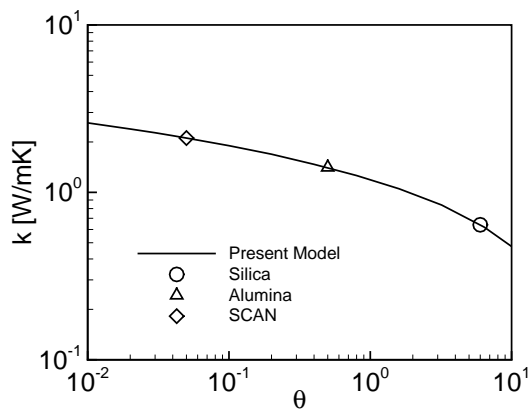

Figure 14. THE EFFECTIVE THERMAL CONDUCTIVITY IS SENSITIVE TO THE VOID ANGLE (SC, $\phi = \phi_{SC} \simeq 52.4\%$) (Data from [10])

ductivity against void angle using the data of [10]. Note that $k_{H\phi} = k(k_m, \theta, \phi)$ so that a mixture of any particles dispersed in the same matrix with the same volume fraction will lie on the curve in Fig. 14.

CONCLUSIONS

The model developed in the present paper has shown good agreement with one set of experiments. This is attributed in part to the use of the void angle as a measure of the degree of particle wetting. A large void angle indicates that the particle-particle interfaces are penetrated to a lesser extent with the matrix material. This is shown to have a significant effect on the prediction of the mixture conductivity, given that the assumptions of the analysis are valid. The void angle was found to range from 1 to 18 degrees. The effect of entrapped air in the mixture has been addressed with a modified definition of the volume fraction. In addition, an approach to modeling the mixture using an effective volume fraction in Maxwell's effective medium theory has shown some promise.

RECOMMENDATIONS

The analysis idealizes the problem and more work is required to develop a comprehensive model. It remains to calculate the void angle from fundamental properties of the constituents of the mixture. In addition, the issues of a particle size distribution, particle geometry, boundary resistance, and the size effect remain to be addressed. More work is being done to address these issues.

ACKNOWLEDGMENT

The authors gratefully acknowledge the financial support of the Centre for Microelectronics Assembly and Packaging (CMAP). We are additionally indebted to the valuable conversations with Professor M. M. Yovanovich and Research Associate Professor P. Teertstra of the University of Waterloo.

REFERENCES

- [1] Tavman I.H., 2000, *Thermal Conductivity of Particle Reinforced Polymer Composites*, Int. Comm. in Heat and Mass Transfer, **27**(2), pp. 253-261.
- [2] Maxwell J.C., 1984, *A Treatise on Electricity and Magnetism (3rd ed.)*, Dover Publications, Inc., USA, **9**, p. 440.
- [3] Devpura A., Phelan P., and Prasher R., 2001, "Size Effects on the Thermal Conductivity of Polymers Laden with Highly Conductive Filler Particles," *Microscale Thermophys. Eng.*, **5**, pp. 177-189.
- [4] Churchill S.W. and Usagi R., 1972, "A General Expression for the Correlation of Rates of Transfer and Other Phenomena," *A. Institute of Chem. Eng.*, **18**, pp. 1121-1128.
- [5] Eucken A., 1932, "Die Wrmeleitfhigkeit keramischer feuerfester Stoffe," *Forsch Geb. Ing. B3*, Forsch., **353**(16).
- [6] Tien C.L. and Vafai K., 1979, "Statistical Bounds for the Effective Thermal Conductivity of Microsphere and Fibrous Insulation," *AIAA Prog. Ser.*, **65**, pp. 135-148.
- [7] Bahrami M., Yovanovich M.M., and Culham J.R., 2004, "Compact Analytical Models for Effective Thermal Conductivity of Rough Spheroid Packed Beds," *ASME Int. Mech. Eng. Congress*, IMECE2004-60129, Anaheim, CA.
- [8] Yovanovich M.M., Schneider G., and Tien C.L., 1978, "Thermal Resistance of Hollow Spheres Subjected to Arbitrary Flux Over Their Poles," Paper No. 78-872, *2nd AIAA/ASME Thermophys. and Heat Transfer Conf.*, Palo Alto, CA.
- [9] Kolodezhnov V.N., Magomedov G.O., Mal'tsev G.P., 2000, "Refined determination of shape for the free surface of the liquid region in analysis of capillary interaction of powder particles," *Colloid J. of the Russian Academy of Sci.: Kolloidnyi Zhurnal*, **62**(4), pp. 443-450.
- [10] Wong C.P. and Bollampally R.S., 1999, "Thermal Conductivity, Elastic Modulus, and Coefficient of Thermal Expansion of Polymer Composites Filled with Ceramic Particles for Electronic Packaging," *J. of App. Polymer Sci.*, **74**, pp. 3396-3403.
- [11] Gowda A., Esler D., Tonapi S., Zhong A., Srihari K., and Schattenmann F., 2004, "Micron and Sub-Micron Scale Characterization of Interfaces in Thermal Interface Material Systems," *Thermal and Thermomech. Phenomena in Elec. Sys.*, **2**, pp. 556-563.